

## DL - 11/14 BASIC TUMBLE DRYERS

### P PROGRAMMER

New P programmer: push buttons to control temperature and time

### OUTSTANDING FEATURES

Reversing drum action as standard  
Galvanized drum as standard  
Frequency inverter as standard

### EFFICIENCY

Big fluff filter

### VERSATILITY

Make to order- customisation  
OPL > Multivending- Standard OPL model easily transformable to coin laundry uses



### ERGONOMICS

Drawer as fluff filter, made of stainless steel  
Biggest door diameters  
Opening sense of door adjustable on site



### MAINTENANCE

Hinged panel: easy and ergonomic access  
Technical menu: statistics, alarm, autotest, data recovery for technicians and maintenance (with console option)



### OTHERS

White painted panels.  
LINT FILTER: filter drawer with wide surface and improved airflow.  
COOL DOWN- anti-wrinkle at the end of the cycle  
Heating options: electric and gas  
CE approved



### OPTIONS

- Opposite door opening
- Display for P programmer
- Ship voltage for electric models: 440V III 50/60 Hz No neutral

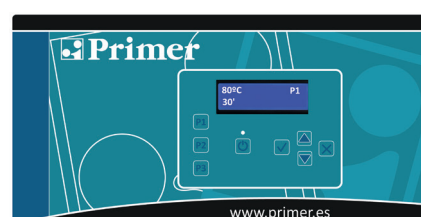

P Control with display

TECHNICAL DATA	UNIT.	DL - 11 P		DL - 14 P	
<b>CAPACITY</b>					
Capacity 1/18	Kg	12		15	
Capacity 1/20	Kg	11		13,5	
Hourly Output BASIC*	Kg/h	23-21		34-30	
Evaporation capacity BASIC*	l/h	14,5		15,40	
<b>DRUM</b>					
Ø Drum	mm	750		750	
Ø Door	mm	574		574	
Door center height	mm	976		976	
Load hole bottom height	mm	689		689	
Drum length	mm	475		610	
Drum volume	l	210		270	
<b>POWER</b>					
Drum motor power	Kw	0,37		0,37	
Fan motor power BASIC	Kw	0,25		0,25	
Electric heating power ALL RANGES	Kw	12		18	
Total electric power (elec.model) BASIC	Kw	12,67		18,67	
Gas heating power ALL RANGES	Kw	20,51		20,51	
Gas heating power (gas model) BASIC	Kw	0,67		0,67	
<b>CONNECTIONS</b>		<b>ELECTRICAL</b>		<b>GAS</b>	
Tension 230V - I + N + T	Nº x mm2 / A	3 x 25 / 63A	3 x 1,5 / 20A	-	3 x 1,5 / 20A
Tension 230V - III + T	Nº x mm2 / A	4 x 10 / 40A	3 x 1,5 / 20A	4x16 /63A	3 x 1,5 / 20A
Tension 400V - III + N + T	Nº x mm2 / A	5 x 4 / 25A	3 x 1,5 / 20A	5x10 / 32A	3 x 1,5 / 20A
Ø Gas inlet	BSP	1/2"		1/2"	
<b>DIMENSIONS / PACKING DIMENSIONS</b>					
Net width / Gross width	mm	785 / 865		785 / 865	
Net Depth / Gross Depth	mm	855 / 940		989 / 1.074	
Net Height / Gross Height	mm	1.694 / 1.840		1.694 / 1.840	
Height without heating battery	mm	-		-	
Net weight / Gross weight	Kg	172 / 180		180 / 190	
<b>OTHERS</b>					
Max airflow BASIC	m3/h	850		850	
Ø Fume exhaust	mm	200		200	
Sound level BASIC	dB	64		64	

\* It may vary depending on the type of heating, filter cleanliness or extraction type.

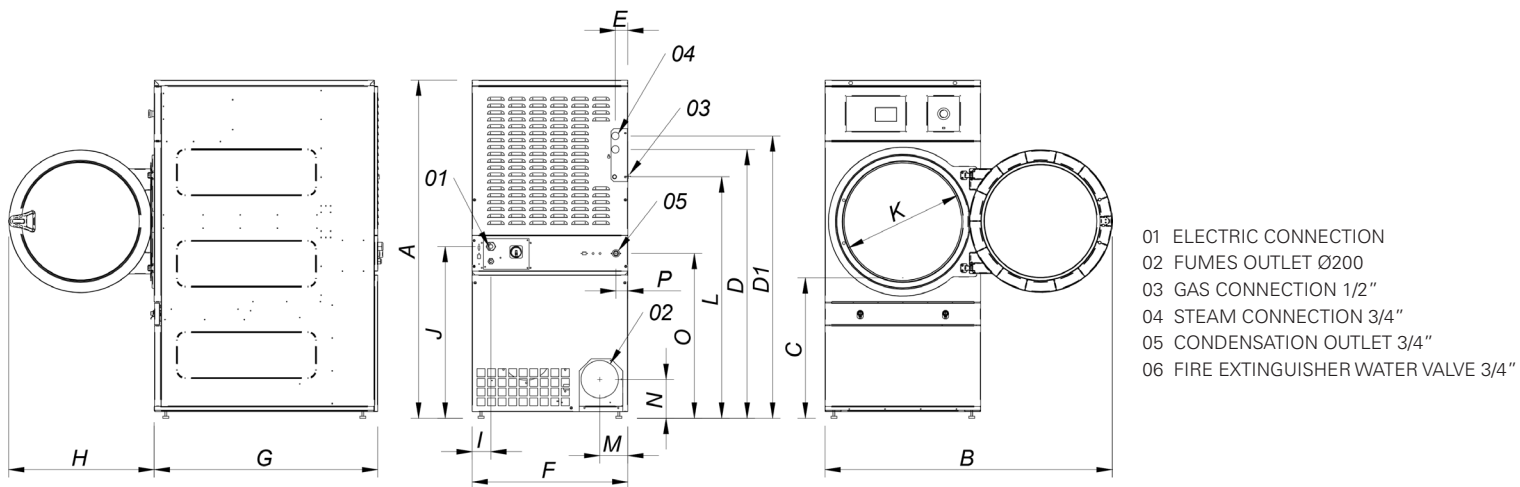

	A	B	C	D	D1	E	E1	F	G	H	I	J	K	L	M	N	O	P
DL - 11	1694	1447	689	1354	1422	68	68	785	855	735	95	870	575	1226	133	180	830	65
DL - 14	1694	1447	689	1354	1422	68	68	785	989	735	95	870	575	1226	133	180	830	65

